

The Power to Surprise

Kia is the newest and most exciting force of change in the automotive world and we are ready to change the way you feel and think about driving. More than just a promise, we are committed to making driving a true pleasure for customers across the globe. With youthful and dynamic styling and the latest in advanced technologies, Kia cars are turning heads the world over with the power to surprise. From the Cerato to the Stinger, Kia offers a full lineup of sedans and SUVs that are not only practical and stylish but downright exhilarating to drive. Keep your eyes on Kia because our best has yet to come.

About Kia Motors Corporation

Kia Motors Corporation (www.kia.com) - a maker of quality vehicles for the young-at-heart - was founded in 1944 and is Korea's oldest manufacturer of motor vehicles. Over 2.7 million Kia vehicles a year are produced at 14 manufacturing and assembly operations in five countries which are then sold and serviced through a network of distributors and dealers covering around 180 countries. Kia today has over 51,000 employees worldwide and an annual revenue of nearly US\$47 billion. It is the major sponsor of the Australian Open and an official automotive partner of FIFA - the governing body of the FIFA World Cup™. Kia Motors Corporation's brand slogan - "The Power to Surprise" - represents the company's global commitment to surprise the world by providing exciting and inspiring experiences that go beyond expectations.

 www.facebook.com/kia.sg

 www.instagram.com/kia_sg

 www.youtube.com/KiaSingapore

 Kia.com.sg / Kia.sg



All information and illustrations are subject to change without notice. Specifications may vary. Please contact Cycle & Carriage Kia Pte Ltd for current information. Body colours shown are only indicative. Visuals shown are for illustration purpose only.

Kia Showrooms
239 Alexandra Road
22 Ubi Road 4
Corporate Showroom
239 Alexandra Road, Level 2 S(159930) Tel: 6470 7377

Kia Service Centres
241 Alexandra Road Tel: 6427 8800
209 Pandan Gardens Tel: 6568 4555
330 Ubi Road 3 Tel: 6746 1000
600 Sin Ming Avenue Tel: 6932 8000

Printed in September 2020



The Power to Surprise



Exceptional Journeys



FROM DREAMS TO REALITY

A new fastback has arrived on the scene and is set to redefine the sports sedan segment. From concept car to reality, the Stinger is a true gran turismo for the modern era. A car for spirited long-distance driving, the Stinger combines high power with handling grace, stunning design with a luxurious and spacious cabin, and on-road comfort with innovative technologies. The Stinger is a car for the journey.

"We've made a lot of great cars and I'm proud of all of them, but the Stinger is something special."

A handwritten signature in red ink, appearing to read 'P. Schreyer'.

Peter Schreyer
President & Chief Design Officer



CLASSIC SPIRIT TUNED FOR MODERN TIMES

Kia's first-ever rear-wheel-drive sports sedan, the all-new turbocharged Stinger, is a five-door fastback that echoes the style and substance of gran turismo legends with its long hood, muscular haunches and stylish spoked wheels, along with serious game-changing performance figures. The Stinger offers an extended wheelbase for maximum cabin space, in addition to driver assistance and entertainment technologies unimaginable during the glory days of muscle cars.



A DREAM CAR FOR RATIONAL PEOPLE

Are you torn between exciting, provocative cars that you've dreamt about from an early age and sensible cars that are a better fit for your everyday life? Rarely has a new car brought both of these extremes together so seamlessly. The Stinger is a car you can dream about all night, then hop into every morning for a drive that is sure to wake up your senses.

A red Kia Stinger is shown in motion on a paved road. The car is positioned in the right half of the frame, moving towards the right. To the left of the road is a stone bridge with a series of columns. The background features a blue sky with white clouds and distant mountains. The overall scene conveys a sense of speed and performance.

PASSION IS BACK WITH A VENGEANCE

To many enthusiasts, the true spirit of gran turismo driving seems to have been lost to the sands of time. Not anymore. From its very inception, the development of the Stinger has always been about passion. For the engineers who took it from the sketchpad to the hairpin turns at Nürburgring, and drivers everywhere with a passion for exhilarating performance, hope has come roaring back. Get ready for the dynamic and provocative Stinger, which promises a driving experience that is more powerful, more agile and more practical than any Kia to date.



PERFORMANCE-BASED SENSATIONS

Performance sedans have an illustrious rear-wheel drive history. Apply the latest technologies and materials to this tradition, and the result is a remarkably responsive, dynamic and rewarding driving experience. The Stinger reflects a deep commitment to capturing the distinctive feel of classic sport sedans. Take a long, meandering ride in the Stinger and see how the right balance of passion and technology can reinvigorate your daily drive.

AN OBSESSION WITH THE DETAILS

All it takes is a single glance to realize that you're in the presence of something more than an attractive sedan. From the wheels and brake calipers to the mirrors, air intakes and the tiger nose grille, the Stinger strikes a chord with enthusiasts everywhere. It is a true celebration of the rear-wheel drive classics of yesteryear, enriched with the latest performance technology.

The Stinger wears its obsessions proudly.



Dark chrome finished outside mirrors The tone of the high-quality side mirror finish puts luxury cars on notice that serious competition has arrived.

Rear LED combination lamps & quad oval exhaust pipes Modern, stylish LED lights illuminate instantaneously with a bright, even glow, while four oval exhaust tips announce that the Stinger is a bona fide performer.

Dark chrome finished trim & 19" alloy wheels (GT only) The dark finish of the trim's chrome conveys refined, performance-oriented luxury, while aggressive 19" alloy wheels speak to the deep gran turismo sentiments of drivers everywhere.

Brembo® Brake System with 18" front and rear discs (GT only) The provocative red Brembo brake calipers make the Stinger look startlingly fast, even at rest.

Full LED headlamps (GT only) Amid classic performance-car styling cues, full-LED headlamps demonstrate that Stinger uses the best technology where it makes sense while still retaining that authentic old-school look.

CLASSIC SIMPLICITY FOR PASSIONATE DRIVERS



From the low-slung driver's seat to intriguing details like the circular, aircraft-inspired air vents, Stinger's cockpit design draws heavily on classic sport sedans. Crucial information appears on a tidy supervision cluster flanked by the tachometer and speedometer, as well as through the Head-Up Display on the windshield. Secondary information appears on the 8-inch "floating" audio and drive-mode display.

Driver and passenger power seats The Stinger comes with a 10-way power adjustable driver's seat and an 8-way power adjustable front passenger seat with 4-way mechanical lumbar support. Particularly for GT trim, the drivers' seat provides maximum comfort with an exclusive aircell lumbar support and side bolster.



Image used is for illustration purposes only.

WHERE PERSONAL SPACE IS PARAMOUNT



Inside, the Stinger feels sporty, substantial and uncluttered. It is also spacious, particularly in the rear, thanks to its long wheelbase. Exclusive to the GT trim, the interior treatment encompasses a soft, luxurious Nappa leather upholstery.

Expansive 2nd row roominess The Stinger offers superior headroom, shoulder room and legroom to its major competitors, providing ample space for two or three passengers to sit comfortably and stretch out.

Wide sunroof Ready to feel the wind in your hair? With the press of a finger, the wide and tilting sunroof lets in far more sunlight and fresh air than a conventional sunroof.





8-speed automatic transmission

Smooth shifts are what you will first notice with the 8-speed automatic transmission. Its algorithms ensure quick and seamless gear changes while helping to maximize fuel efficiency.

INGENUITY THAT PACKS A PUNCH

Stinger powertrains set a higher standard for longitudinal, rear-wheel-drive orientation, leveraging technology to achieve remarkable combustion efficiency. Each powerplant is designed to offer the thrilling feel of rear-wheel propulsion when you step on the accelerator, even at low engine speeds. An 8-speed automatic transmission redefines smoothness, giving the Stinger an intelligent and luxurious twist on gran turismo traditions.



0-100 km/h*



Max. speed*



Max. power*

* Lambda 3.3 T-GDI engine (GT only)

Lambda 3.3 T-GDI engine (GT only) A twin turbocharger helps this top-of-the-line V6 engine achieve considerable torque over a broad rpm range. The exhaust manifold is integrated with the cylinder head for added power, and an electronic thermostat helps provide precise temperature control.

Theta II 2.0 T-GDI engine (GT Line only) A twin-scroll turbocharger boosts low- to mid-rev efficiency while newly applied technologies provide phenomenal combustion efficiency. The engine produces maximum power output of 247 ps at 6,200 rpm and maximum torque output of 353 Nm at 1,400 rpm.





► **Rack-mounted motor driven power steering (R-MDPS)**

R-MDPS offers the driver quicker responsiveness thanks to the mounting of the electric motor directly on the steering rack. Steering boost is adjusted indirectly through the five drive modes.

► **19-inch tyres (GT only)**

The low profile 19-inch tyres offer an outstanding blend of dry and wet street traction and handling.

► **Rear differential (GT only)**

The optional mechanical limited slip differential provides agility during high speed cornering.

► **Electronically-controlled suspension (ECS) (GT only)**

ECS uses multiple sensors and an ECU to evaluate vehicle speed, road conditions, cornering, stopping requirements and acceleration. Using this data, ECS regulates vertical suspension travel to optimize road feel in real time.

INTELLIGENT DISTRIBUTION OF POWER

Stinger combines the thrilling rear-drive motoring found in classic muscle cars with the all-weather benefits of modern vehicle stability technology, making it a car that is exciting to drive while offering confident, carefree driving on snowy, icy and wet roads. With its Anti-Lock Braking System and Electronic Stability Control, Stinger helps the driver to retain directional control under a variety of road-surface conditions.

Electronic Stability Control (ESC) ESC ensures optimal braking performance and directional control by automatically delivering the right amount of braking force to each wheel based on evaluation of engine torque and driving circumstances.

Drive Mode Select (DMS) The Stinger's DMS includes five modes, accessible from a dial behind the shift lever, that change the driving characteristics by automatically adjusting how the engine, transmission, suspension and steering operate, and even altering the engine sound.





SUPPORTIVE BUT NOT OVERBEARING

The Stinger offers substantial stability management for a sports sedan, while giving the driver more choices as to how much or how little control to leave to the ECU. Drivers can choose from five drive modes, each with its own coordinated combination of dynamic characteristics. There is even a Launch Control mode that momentarily suspends ESC to ensure rapid acceleration with minimal wheel slip and maximum torque control.

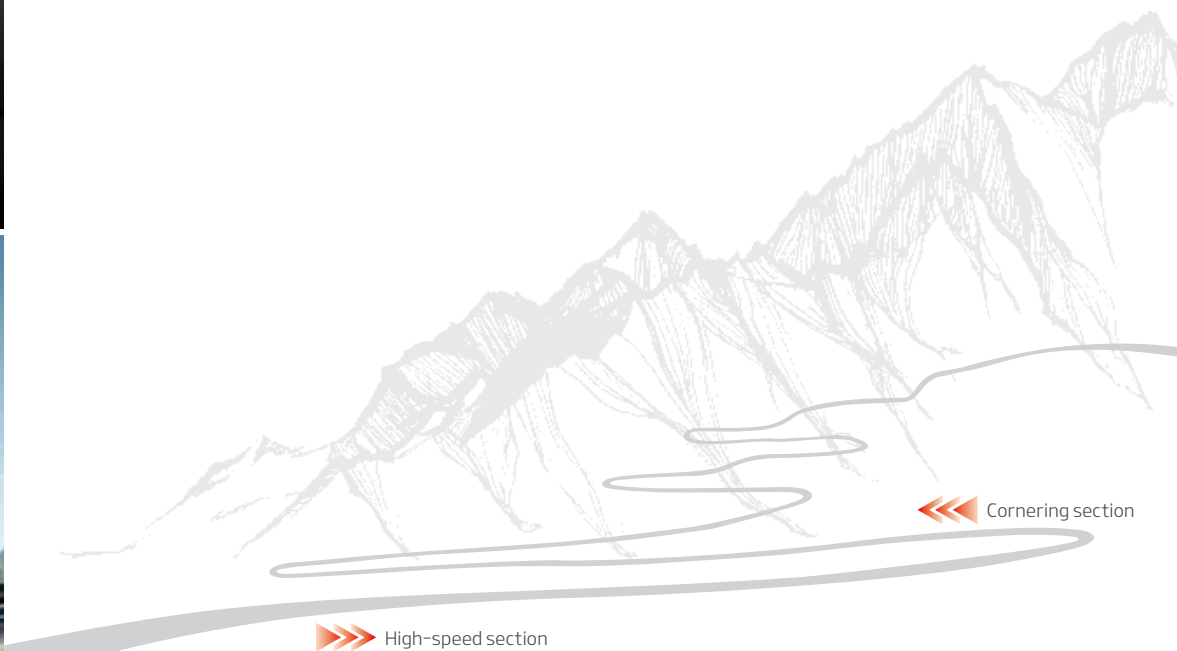



TRUE CHARACTER UNFOLDS
ON WIDE-OPEN ROADS



Smart Power Tailgate

It's a breeze loading cargo even when your hands are full. The lid of the Smart Power Tailgate opens automatically within three seconds when you stand close to the rear of the vehicle with the key in your possession.



A WORLD OF POSSIBILITIES



The Stinger puts your life in motion in countless new ways. With a 406 litres of cargo capacity, there is plenty of accessible space perfect for a long road trip. The rear hatch lifts to reveal a broad opening, making it easier to load wide objects or arrange cargo. The rear seatbacks split and fold 60:40, giving you several options for accommodating longer items.

406l cargo capacity

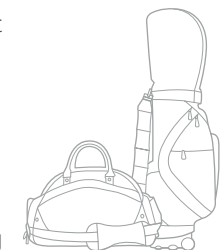

INTUITIVE PROBLEM-SOLVING

DRIVE WISE is Kia's ADAS (Advanced Driver Assistance System) technology initiative dedicated to delivering driving pleasure and the utmost in occupant and pedestrian safety by taking over the tedious and complex tasks traditionally left to drivers. The Stinger offers many DRIVE WISE assistance technologies that use advanced sensor and processing technology to help make driving as safe and convenient as possible.

Driving Assist Systems



Blind Spot Detection (BSD) (GT only)

Traffic can move in complex ways, and at disparate speeds. No matter how careful you are, it can be difficult to stay on top of how clear the adjacent lanes are from second to second. Using radar to monitor the sides and rear of the vehicle, Blind Spot Detection (BSD) employs visual alerts on the side view mirror to inform the driver about vehicles in the blind spot for easier and safer lane changes.



Rear Cross-Traffic Alert (RCTA) (GT only)

Enjoy peace of mind whenever you back the Stinger out of a parking spot or driveway. Its RCTA system uses radars to detect the presence of cross traffic in the lane your vehicle is entering. If it senses vehicles approaching from either the right or the left, it will give you an audible warning until the path is clear for you.



► **Tailgate opening fortifications**

Stronger box-section joints between the rear quarter panels, back panel and hatch rim improve stiffness.

► **Quarter panel reinforcement connections**

Reinforced quarter panels above the rear wheels now join the body at a higher point for improved stiffness.

► **Stronger underbody rail materials**

The safety cage formed by the seat cross members, longitudinal members and side sill inner panels is greatly reinforced.

► **Stiffer subframe panel joints**

Bulkheads within the subframe side members now join four surfaces instead of three for maximized stiffness.



Phenomenal torsional rigidity and hot-stamped steel

The steel members of the Stinger body are engineered for substantial torsional rigidity, or resistance to twisting forces, so that bumps and jolts in the road are absorbed with precision, while impact forces during a collision are managed in ways that better protect the occupant space.

21 Hot-stamped components | 173 Meters of advanced adhesives

THE SCIENCE OF PROTECTION

Safety is an integral part of any vehicle's performance, and the Stinger is engineered to prioritize driver and passenger protection above all else. Occupant protection is built into every aspect of the chassis and body, and was taken into account by Kia engineers as they optimized aerodynamics, performance, ride smoothness, and everything else that goes into creating an exceptional vehicle. The result is a thrilling five-door fastback sedan designed to offer an exceptional level of safety.

Advanced 7-airbag system To help protect occupants and potentially reduce injuries in the event of a collision, the Stinger offers driver and front passenger airbags, two front-side airbags, two side-curtain airbags and a driver's knee airbag.

Knee airbag The driver's knee airbag is designed to minimize impact and injury to the driver's lower extremities in the event of a collision.





FACE THE FUTURE
INSPIRED BY THE PAST



8-inch touchscreen infotainment system with Apple Car Play

Refreshingly easy to read and operate, the vivid “floating” 8-inch infotainment system with Apple Car Play connectivity combines important vehicle information with controls for the state-of-the-art sound system that can play audio files from connected devices. The screen also displays the view from the rear view camera, and provides dynamic guidelines to help you back gracefully into and out of parking spaces and driveways.

INFORMATION IN CLEAR SIGHT

Designing the ideal driving experience requires packaging all of today’s technologies in a clear, simple and satisfying way. The Stinger boasts a wealth of high-tech driving, safety and entertainment features that did not exist in the old days of gran turismo motoring. Yet the cockpit design is simple and classic, allowing the driver to focus on the road. The Head-Up Display and floating 8-inch infotainment system convey information in an ingenious yet tasteful way.



Head-Up Display (HUD)

With the customizable Head-Up Display (HUD), key driving information is discretely projected onto the windshield in your line of sight so that you can safely focus on the road ahead. Visible day or night, the height-adjustable display appears to float just in front of the car. Vehicle speed, cruise control, audio and Blind Spot Detection information are included.



7" supervision cluster Vital vehicle and driving information appear in a larger, more vivid and higher-definition format on the 7-inch TFT LCD supervision cluster located between the tachometer and the speedometer. Multi-language support is included.

Wireless smartphone charger Charge a compatible mobile phone wirelessly on the charging pad located at the front of the center console. An orange display indicates charging in progress while green indicates a full charge. You will be alerted when exiting the vehicle if a device is left on the charging pad.

SUBLIME SOPHISTICATION

You spend a lot of time in your car. So why not tailor the Stinger's interior to match your take on the ideal modern gran turismo? The Stinger has a surprisingly long list of impressive standard features, but for the utmost enjoyment, choose from a variety of premium comfort, entertainment and convenience options.



15 - SPEAKER Harman/Kardon premium sound system (GT only)

The Harman/ Kardon sound system includes subwoofers that resonate in hollow parts of the frame and body. Clar-Fi technology enhances digitally compressed music while Active Sound Design augments acceleration, shifting and suspension sounds for an enhanced driving experience.



Paddle shift levers Standard paddle shift levers let you make quick gear changes for the 8-speed automatic transmission without taking your hands off the steering wheel. It is a simple way to access more torque on short notice or choose your own shift points during vigorous driving.



Electronic parking brake (EPB) An electronic parking brake offers quick, secure activation without the effort required by traditional mechanical brake levers. Pull on the EPB switch on the center console to activate the parking brake. Auto Hold mode temporarily maintains the vehicle at a standstill even if the brake pedal is released.



Heated and ventilated front seats & heated rear seats On colder days, the heated front seats provide comfort, while air blown through the seats keep you cool on warmer days. Both the seat cushion and the seatback feature airflow perforations to keep more of the body in a state of comfort.



Dual-zone automatic climate control The dual climate control gives the driver and front passenger separate controls for temperature and fan speed.



Integrated Memory System (IMS) The Integrated Memory System saves two presets for driver's seating positions, outside rear-view mirrors, Head-Up Display and cluster display. It's a simple way to keep the Stinger totally personalized, yet flexible enough to make another driver feel at home.

► Side-bolster adjustment (GT only)

The side-bolster adjustment for the 8-way power driver seat lets you choose a setting that offers maximum support and comfort by twisting the seat controls on the side of the base of the seat.

► 4-way Air Cell Lumbar Support (GT only)

The Air Cell Lumbar Support for the 8-way power driver seat lets you reposition areas of resistance in the seatback, up-and-down and side-to-side, for maximum comfort and support.

► Cushion extension (GT only)

To help relieve fatigue, the thigh extension for the driver moves the front edge of the seat base forward, supporting a larger area of the driver's thighs.



FLUIDITY IN MOTION

The great thing about designing a modern sports sedan is having the opportunity to capture classic style while having a clean slate to apply the latest aerodynamics enhancing and noise reduction technologies. The Stinger is shaped to minimize fuel-consuming drag while maximizing stability and control. At the same time, its structure, contours and interior treatments are engineered to isolate passengers from noise and vibrations.



Front-bumper-integrated air curtain & aero fender garnish An air curtain that helps manage airflow, reduce drag and direct cooling air to the radiator is integrated into the front bumper. Lower apertures direct airflow to the wheel wells, helping to cool the brakes. In addition to the fuel savings and noise reduction that accompany reduced drag, the air dam's contours improve driving stability. Meanwhile, the aero fender garnish pays tribute to classic design cues of high-performance sports cars.



Rear integrated diffuser An integrated diffuser panel beneath the rear bumper helps to control airflow leaving the underside of the body, preventing the four exhaust pipes from creating drag under the car. It pays homage to racing diffusers which lower the turbulence that can occur when low-pressure air under the car meets higher pressure ambient air. Longitudinal ridges help provide directional stability.



Lipped trunk lid edge To improve stability and optimize the vortex of potentially turbulent air that forms behind the Stinger when it travels at higher speeds, the trailing edge of the trunk lid features an aerodynamic lip that provides a spoiler effect along with a pleasing aesthetic design detail.

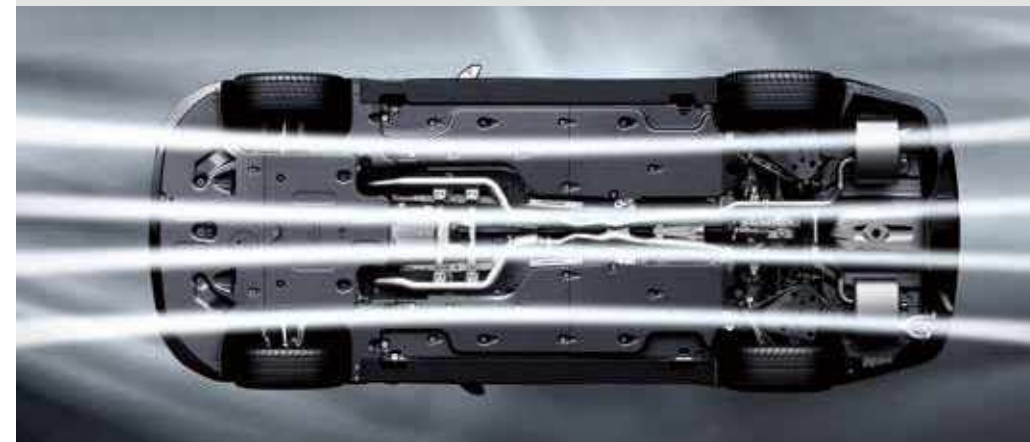

Multiple aerodynamic underbody covers The aerodynamic contours everyone can see in the silhouette and panels of a car are familiar to most people. But just as important to the aerodynamics equation is how air disperses underneath the vehicle, where the components often have complex contours that can result in drag. For this reason, the Stinger uses a system of sturdy underbody covers below the engine and transmission, on each side of the cabin and on each side of the rear suspension. These covers reduce airflow resistance of the underside of the body when travelling at higher speeds.



Noise, vibration & harshness (NVH) Inside and out, new insulation materials abound, and every element of the Stinger has been engineered to raise the standard for a smooth, quiet ride. The engine room and dash get extra insulation while padding quiets joints of the body pillars and frame. The exhaust has been reconfigured, and the rear cross-member stiffened, while side mirrors and doors are sculpted to minimize noise and drag.

DEEPLY PERSONAL ALLURE

The inviting Stinger interior reflects the spirit of the gran turismo concept. Rich, luxurious tones complement the bold exterior colors. Contrast stitching and real aluminum add a refined touch. Choose Nappa leather upholstery on the GT variant or pure leather on the GT Line.

Center Console Garnish



Carbon Insert Film

Black One-tone Interior



GT only
Black Nappa Leather



GT Line only
Black Leather Upholstery

Red Color Package



GT only
Red Nappa Leather



GT Line only
Red Leather Upholstery

Exterior Body Colors

Snow White Pearl (SWP)



Silky Silver (4SS)



Ceramic Silver (C4S)



Panthera Metal (P2M)



Aurora Black Pearl (ABP)



Deep Chroma Blue (D9B)



Micro Blue (M6B)



Hi Chroma Red (H4R)



Lake Stone (L5S)



Neon Orange (N2O)



225/45R
18" Alloy Wheel (B-type)
GT Line only



225/40R (Front) | 255/35R (Rear)
19" Alloy Wheel (B-type)
GT only

Technical Specifications

Engines		Theta II 2.0 T-GDI engine	Lambda 3.3 T-GDI engine
Displacement	cc	1,998	3,342
Max. power	ps/rpm	247 / 6,200	370 / 6,000
Max. torque	Nm/rpm	353 / 1,400	510 / 1,300
Performance			
0-100 km/h	seconds	6.0	4.9
80-120 km/h	seconds	4.4	3.3
Top speed	km/h	240	270
CO2 emission	g/km	181	225
Fuel consumption	ℓ/100km	7.9	9.9
VES Banding		C1	C2
Cargo Capacity			
Trunk volume (VDA)	ℓ	406	

Dimensions			
Overall length	mm	4,830	
Overall width	mm	1,870	
Overall height	mm	1,400	
Wheelbase	mm	2,905	
Wheel tread	Front	mm	18": 1,596 / 19": 1,596
	Rear	mm	18": 1,647 / 19": 1,619
Head room	Front	mm	974
	Rear	mm	939
Leg room	Front	mm	1,083
	Rear	mm	925
Shoulder room	Front	mm	1,433
	Rear	mm	1,391

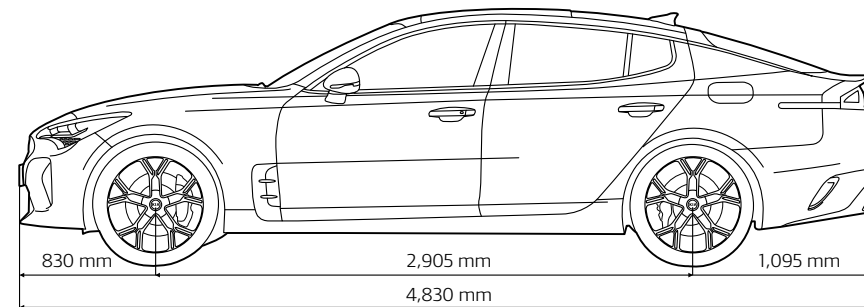
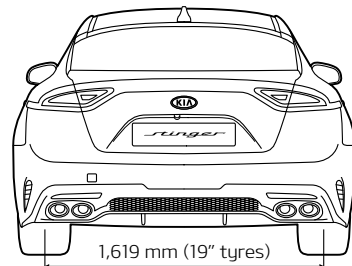
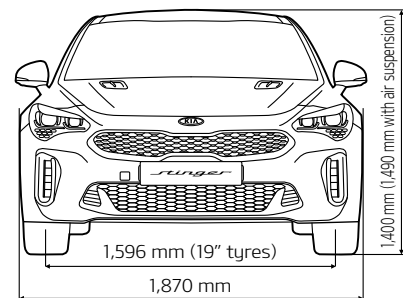

Fuel Consumption: Stinger GT 3.3L (9.9L/100km), Stinger GT Line 2.0L (7.9L/100km). CO2 Emission: Stinger GT 3.3L (225g/km), Stinger GT Line 2.0L (181g/km). VES Banding: Stinger GT 3.3L (C3), Stinger GT Line 2.0L (B)
 All information and illustrations contained in this brochure are based on data available at the time of publication and are subject to change without notice.
 © 2017 Kia Motors Corporation. Reproduction of the contents of this material without the permission of Kia Motors Corporation is prohibited.

Cycle & Carriage After-sales Service keeps your car in its prime

We care for you the same way we care for our family. Experience the Cycle & Carriage Kia Service spirit as we welcome you at our Kia Service Centres.

With more than a century of experience in the automotive industry, we can assure you that you will enjoy the most comprehensive customer support and first-class service from well-trained professionals, using state-of-the-art technologies, diagnostic tools and Grade A genuine parts to keep your Kia vehicle running in peak condition. All Kia genuine parts come with a 1-year or 20,000 km (whichever comes first) warranty.

This is our commitment to you.



Get unsurpassed assurance from Kia

We are confident of the quality and durability of every Kia vehicle, having carried out stringent pre-delivery processes and checks before the car is delivered in pristine condition. Additionally, your new Kia car will enjoy a 5-year unlimited mileage warranty and a 10-year engine warranty.

From the date of registration, your new Kia car is covered against defects in materials and workmanship for a period of 5 years of unlimited mileage. On top of that, starting from 1 June 2014, your Kia car will come with a 10-year engine warranty, subject to a maximum mileage of 200,000km or 10 years, whichever is earlier. This engine warranty will take effect immediately after the expiry of the manufacturer's.

5 YEAR
UNLIMITED
MILEAGE WARRANTY

10 YEAR
ENGINE
WARRANTY

stinger



Kia Stinger Features



Brembo® Brake System with 18" front and rear discs (GT only)



Electronically-Controlled Suspension (ECS) (GT only)



Head-Up Display (HUD)

Technical Data

2.0ℓ GT Line

3.3ℓ GT

- Displacement (cc) 1,998
- Engine Type Theta II 2.0 T-GDI
- Max Power (ps/rpm) 247 / 6,200
- Max Torque (Nm/rpm) 353 / 1,400-4,000
- 0 - 100 km/h (s) 6.0
- Fuel Consumption (ℓ/100km) 7.9
- CO2 Emission (g/km) 181
- Fuel tank (ℓ) 60
- VES Banding C1

- Displacement (cc) 3,342
- Engine Type Lambda 3.3 twin-turbo V6
- Max Power (ps/rpm) 370 / 6,000
- Max Torque (Nm/rpm) 510 / 1,300-4,500
- 0 - 100 km/h (s) 4.9
- Fuel Consumption (ℓ/100km) 9.9
- CO2 Emission (g/km) 225
- Fuel tank (ℓ) 60
- VES Banding C2

- Overall length (mm) 4,830
- Overall width (mm) 1,870
- Overall height (mm) 1,400
- Wheelbase (mm) 2,905
- Minimum turning radius (m) 5.6
- Top Speed (km/h) 240 (GT Line)
270 (GT)

10
YEAR
ENGINE
WARRANTY

5
YEAR
UNLIMITED
MILEAGE WARRANTY



J.D. Power
Highest Ranked Mass Market
Brand in Initial Quality Study
6 Years in a Row

All information are subject to changes. Specifications may vary.



The Power to Surprise



Exceptional Journeys

SPECIFICATIONS

PERFORMANCE	GT Line	GT
Drive Mode Select System with 5 modes (Eco, Comfort, Sport, Sport Plus, Smart)	●	●
Launch control	●	●
8-speed automatic transmission with steering mounted paddle shifters	●	●
Brembo® Brake System with 18" front and rear discs (GT only)	-	●
Electronically-Controlled Suspension (ECS)	-	●
Mechanical Limited-Slip Differential	-	●
Variable Gear Ratio Rack Mounted Motor Driven Power Steering	-	●
EXTERIOR	GT Line	GT
Alloy sports rims	18"	19"
LED headlamps	●	With Dynamic Bending Light
Chrome quad exhaust tailpipes	●	●
Dark chrome radiator grille and mirror cover	●	●
LED daytime running lights	●	●
LED rear combination lamps	●	●
LED rear fog lamps	●	●
Aeroblade wipers	●	●
INTERIOR	GT Line	GT
Leather upholstery	●	Nappa leather
D Cut steering wheel with perforated leather	●	●
8" touchscreen infotainment system (Apple CarPlay and Android Auto Connectivity)	●	●
Sunroof with tilt function	●	●
Suede roof lining and sunvisors	●	●
Aluminium pedals	●	●
LED interior lighting and mood lamps	●	●
7" TFT-LCD supervision cluster	●	●
Luggage net	●	●
COMFORT AND CONVENIENCE	GT Line	GT
Smart Power Tailgate with tailgate memory function	●	●
Heated and ventilated front seats	●	●
Button start/stop with keyless entry system	●	●
Head-Up Display (HUD)	●	●
10-way power adjustable driver's seat with 2 memory settings	●	●
8-way power adjustable front passenger seat with 4-way lumbar support	●	●
Electric tilt and telescopic steering wheel	●	●
Electrochromic rear-view and side mirrors	●	●
Wireless smartphone charger	●	●
Integrated steering wheel controls	●	●
Bluetooth connectivity	●	●
Dual-zone automatic climate control	●	●
Auto light control and rain sensor	●	●
Shift-by-wire transmission control	●	●
Harman/Kardon Premium 15-speaker sound system	-	●
Heated rear seats	-	●
SAFETY AND SECURITY	GT Line	GT
Advanced 7-airbag system	●	●
Front and rear parking sensors	●	●
Electronic Parking Brake (EPB) with auto hold function	●	●
ISOFIX	●	●
Anti-lock Braking System (ABS)	●	●
3-point seatbelts	●	●
Hill-start Assist Control (HAC)	●	●
Electronic Stability Control (ESC)	●	●
Blind Spot Detection (BSD)	-	●
Rear Cross-Traffic Alert (RCTA)	-	●

Images used are for illustration purposes only. All Kia passenger vehicles are covered by a 5-year unlimited mileage factory warranty and a 10-year engine warranty. All specifications are subject to change without prior notice from Cycle & Carriage Kia Ptd Ltd. Printed in September 2020.

Kia Showrooms
239 Alexandra Road
22 Ubi Road 4

Tel: 6866 1666
Tel: 6746 2000

Corporate Showroom
239 Alexandra Road, Level 2

Tel: 6470 7377



www.facebook.com/kia.sg



Kia.com.sg / Kia.sg